

JERRYCAN 500ml

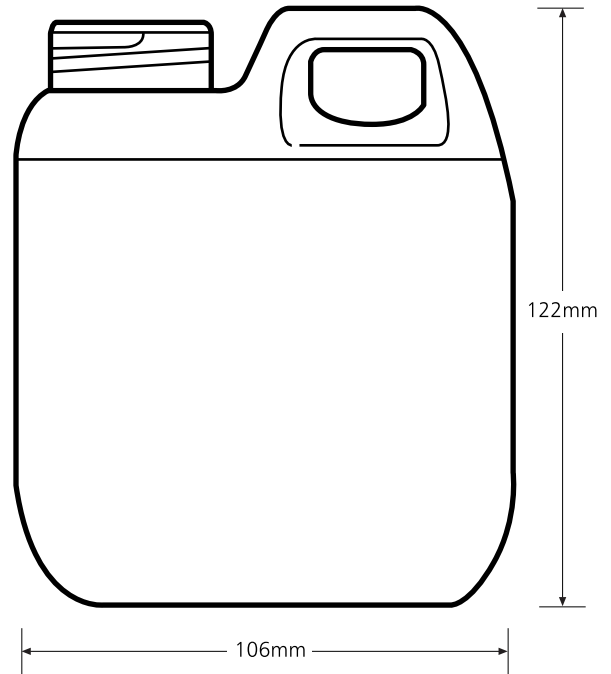

Container

Size	Material	Weight	Neck Finish	UN Approval	No. Pallet
500ml	HDPE	25g +/- 2	38mm R3	BRC Approved	1368 (8 layers)

Applications:

Agrochemical, Automotive, Food & Drink, Household, Industrial, Janitorial / Cleaning Chemicals, Medical, Personal Care, Pet Care, Pharmicare.

Nexus Packaging Ltd.

7 Centurion Business Park, Shields Road, Glasgow, G41 1HH
 Tel: 0141 429 2525 | Fax: 0141 429 2060 | Email: admin@nexpack.co.uk

REGISTERED IN SCOTLAND: No. SC262044 | VAT No. 829 6449 83